

| REV | DESCRIPTION OF REVISION | E.C.N. | BY | APPROVED | DATE |
|-----|--|--------|--------|----------|----------|
| A | CORRECTED P/N: CW-45-015 -DB002A B.203 RoHS | | E.T.W. | B.D. | 01-20-10 |

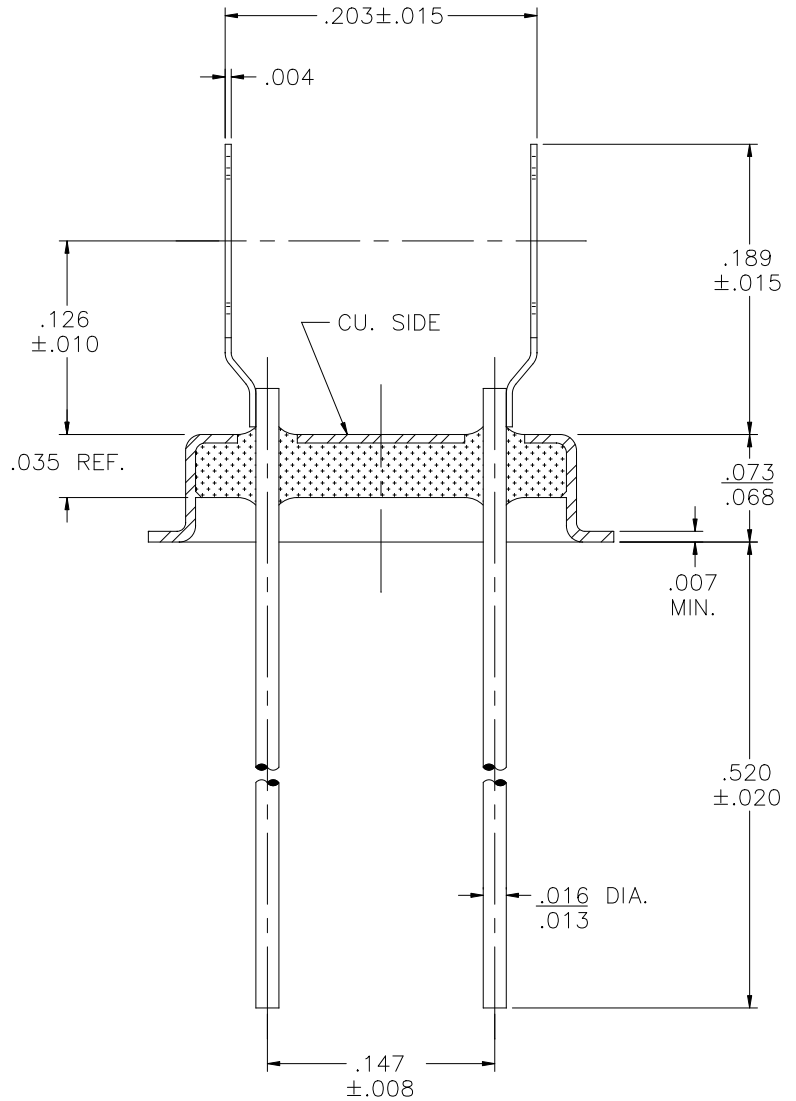
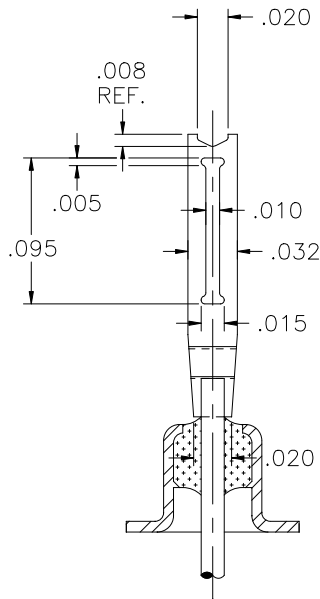
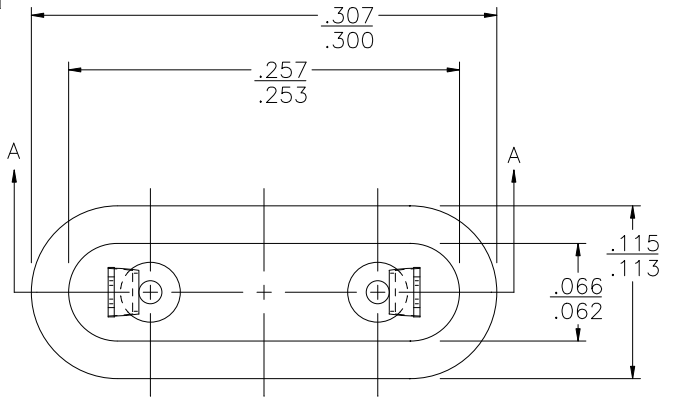

SECTION A-A

MATERIAL:

EYELET- 30/70 COPPER CLAD KOVAR.
GLASS - 7052 OR EQUAL.
LEADS - ASTM F-15 ALLOY, KOVAR.
MOUNT- C770 NICKEL SILVER, 1/2 HARD.

PLATING:

1. OPTION: RoHS COMPLIANT ELECTROLESS NICKEL PLATE OF 100 MICROINCHES MINIMUM FINAL PLATE.
2. OPTION: RoHS COMPLIANT ELECTROLESS NICKEL PLATE OF 100 MICROINCHES MINIMUM FOLLOWED BY A RoHS COMPLIANT LEAD FREE SOLDER COAT, ON LEADS ONLY.
3. OPTION: RoHS COMPLIANT ELECTROLESS NICKEL PLATE OF 100 MICROINCHES MINIMUM FOLLOWED BY A GOLD FLASH OF .99999 PURE 24 KARAT GOLD UP TO A MAX. OF 8 MICROINCHES.

| | | | | | | | | |
|---------------------------------|---|------------|-----------|--|---------------------------------------|---|--|---|
| DRAWN BY: E.T.W. 03-28-06 | MATERIAL: SEE ABOVE | | | TOLERANCING PER ANSI Y14.5 .X ±.005 .XXX ±.005 .XX ±.005 ANG ±5° UNLESS OTHERWISE SPECIFIED | |  Legacy Technologies Inc. 6700 W. 47th TERR. MISSION, KS. 66203 TEL: 913-432-2487 FAX: 913-432-0570 | PART NUMBER: CW-45-015A-DB002A B.203 RoHS | A |
| CHECKED BY: | APP. SPECS | SUPERSEDES | NEXT ASSY | SCALE: 8:1 | FINISH: UNLESS OTHERWISE SPECIFIED | | | |
| APPROVED BY: | TITLE: HC-45/U W/ DOG BONE MOUNT FOR A .220 DIA. BLANK A SUBSTITUTE FOR L.T.I. / KANE P/N: 445-0100-1233-919 RoHS | | | | | | | |